

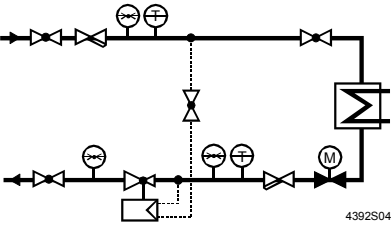

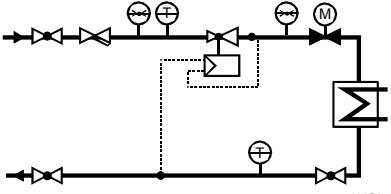

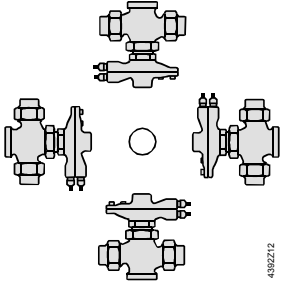
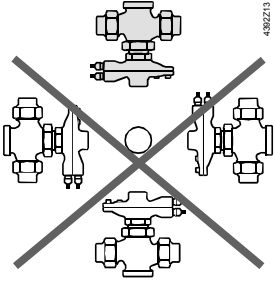
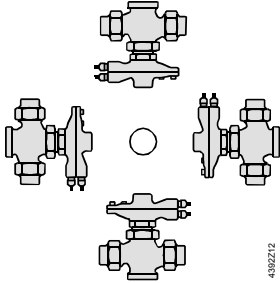
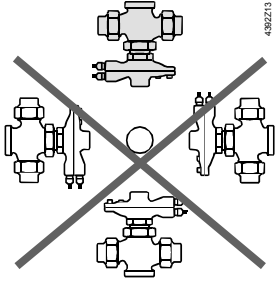

de	Einbau	Installation	en
	<p>Einbaubeispiele Installation examples</p> <ul style="list-style-type: none"> Einbau im Rücklauf Return side installation  <p>4392S04</p> <ul style="list-style-type: none"> Einbau im Vorlauf Flow side installation  <p>4392S05</p>	<ul style="list-style-type: none"> Clean pipeline system prior to assembly. The installation of a strainer in front of the regulator is strongly recommended. Install pressure indicators in front of and behind the system part to be controlled. The regulator may be installed in the supply or the return pipes. 	
<ul style="list-style-type: none"> Einbaulage <p>Mediumtemperatur < 90 °C</p>  <p>4392Z12</p> <p>Mediumtemperatur > 90 °C</p>  <p>4392Z13</p>	<ul style="list-style-type: none"> Orientation <p>Medium temperatur < 90 °C</p>  <p>4392Z12</p> <p>Medium temperatur > 90 °C</p>  <p>4392Z13</p>	<ul style="list-style-type: none"> Mechanical loads of the valve body by the pipelines are not permitted. 	
<ul style="list-style-type: none"> Mechanische Belastungen des Ventilgehäuses durch die Rohrleitungen sind nicht zulässig. 		<ul style="list-style-type: none"> Mechanical loads of the valve body by the pipelines are not permitted. 	
<ul style="list-style-type: none"> Die auf dem Ventilkörper angezeigte Durchflussrichtung ist zu beachten. 		<ul style="list-style-type: none"> The flow direction indicated on the valve body must be followed. 	
<p>Achtung !</p> <ul style="list-style-type: none"> Das Ventil mit angeschraubten Anschweissenden ALS... darf in der Rohrleitung nur angeheftet werden. Das Einschweissen der Anschweissenden ist nur zulässig ohne Ventil und Dichtungen. Bei Nichtbeachtung zerstören die hohen Schweißtemperaturen die Dichtungen des Ventils. 	 <p>4393Z04</p>	<p>Caution !</p> <ul style="list-style-type: none"> The valve with mounted welded fittings (ALS...) may only be pinned to the pipeline. The welded fittings may be welded only without the valve and seals. If these instructions are not complied with, high welding temperatures may destroy the seals. 	

de	Steuerleitungsanschluss	Control pressure lines	en
<ul style="list-style-type: none"> Es wird empfohlen, den Steuerleitungsanschluss an der Rohrleitung waagrecht anzubringen. Verschmutzungen in der Steuerleitung und mögliche Funktionsstörungen des Reglers werden dadurch vermieden. 		<ul style="list-style-type: none"> We recommend to install the pressure lines to the pipeline in an horizontal position. This avoids dirt in the control line and possible malfunction of the regulator. 	
<ul style="list-style-type: none"> Der Steuerleitungsanschluss ist gemäss der nebenstehenden Zeichnung auszuführen. 		<ul style="list-style-type: none"> We recommend to realise the pressure lines connection as shown in the picture. 	
<ul style="list-style-type: none"> Verwenden Sie nur die original Siemens-Steuerleitungen ALP16 oder ALP25. Kürzen Sie die Steuerleitungen nicht, die Dichtigkeit der Verbindung zum Druckregler kann sonst nicht mehr sichergestellt werden. 	<ul style="list-style-type: none"> Use only the original ALP16 or ALP25 pressure lines and the original neck. Do not shorten the pressure line. Tightness of sealing at the connection is not guaranteed. 		
<ul style="list-style-type: none"> Die (+) Steuerleitung (Cu-Rohr Ø3x1) ist am (+) Anschluss des Antriebes und vor dem zu regelnden Anlagenteil anzuschliessen. Die (-) Steuerleitung (Cu-Rohr Ø3x1) ist am (-) Anschluss des Antriebes und nach dem zu regelnden Anlagenteil anzuschliessen. 		<ul style="list-style-type: none"> Connect the (+) control line (Cu pipe Ø3x1) to the (+) lower connection of the actuator in front of the system part to be controlled. Connect the (-) control line (Cu pipe Ø3x1) to the (-) upper connection of the actuator behind the system part to be controlled. 	
<ul style="list-style-type: none"> Überwurfmutter anziehen (Drehmoment = 10 Nm) 		<ul style="list-style-type: none"> Tighten union nut (Torque = 10 Nm) 	

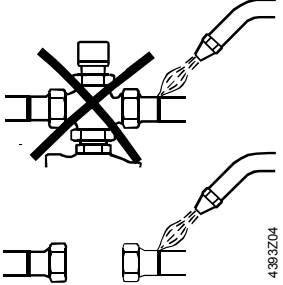
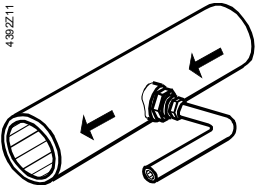
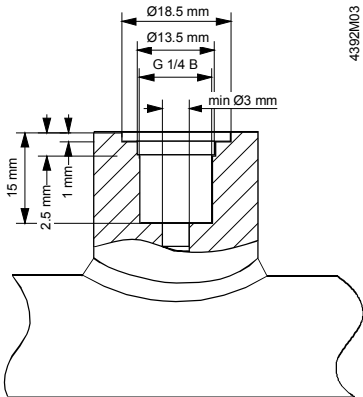
de	Vorbereitung	Preparation	en
<p>Achtung ! Zur Vermeidung von zu hohen Druckdifferenzen am Regler, ist beim Öffnen der Absperrarmaturen folgende Reihenfolge zu beachten:</p> <ul style="list-style-type: none"> In den Steuerleitungen eventuell vorhandene Absperrventile öffnen (1). Armaturen in der Anlage öffnen (2). Absperrarmatur im Vorlauf und Rücklauf langsam öffnen (3). 		<p>Caution ! To avoid too high pressure differences on the regulator, observe the following sequence when opening the shut off valves:</p> <ul style="list-style-type: none"> Open shut off valves, if any are in the control lines (1). Slowly open shut off units in the plant (2). Slowly open shut off valves in the supply and return pipes (3). 	

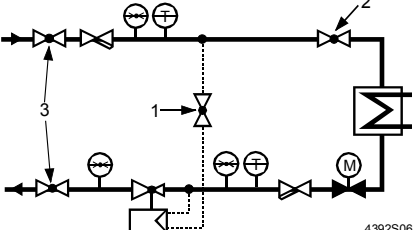
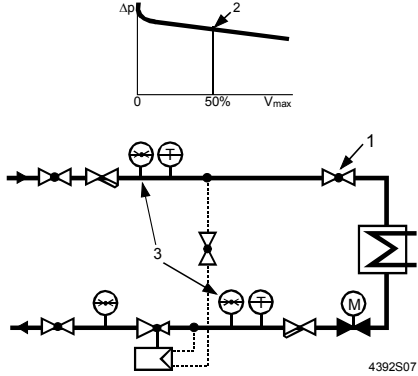
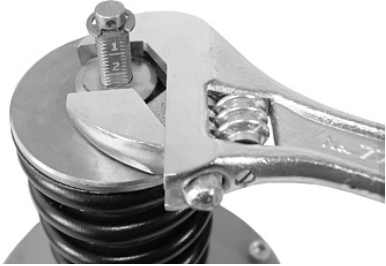
de	Dichtheits- und Druckprüfung	Leak and pressure tests	en
	<ul style="list-style-type: none"> • Vor einer Dichtheitsprüfung oder Druckprüfung sind die Armaturen nach Abschnitt «Vorbereitung» zu öffnen. • Eventuell für die Gesamtanlage erforderliche Druckprüfung ist nach den Vorgaben des Anlagenherstellers vorzunehmen. 	<ul style="list-style-type: none"> • Proceed in accordance with paragraph «Preparation» before leak or pressure tests. • A pressure test of the entire system must be carried out in accordance with manufacturer's instructions. 	
de	SollwertEinstellung	Setpoint setting	en
	Sollwertbereich siehe Typenschild.	Setpoint range see type label.	
<ol style="list-style-type: none"> 1. Alle Armaturen in der Anlage ganz öffnen. 2. Volumenstrom an einer Armatur (1), über die der Differenzdruck geregelt wird, auf ca. 50 % einstellen. 		<ol style="list-style-type: none"> 1. Completely open all shut off devices in the system. 2. Set flow rate at a valve (1) by which differential pressure is controlled, to about 50 %. 	
<ol style="list-style-type: none"> 3. Einstellung: Druckanzeigen (3) beachten. Rechtsdrehung erhöht den Sollwert (Feder spannen). Linksdrehung reduziert den Sollwert (Feder entspannen). 		<ol style="list-style-type: none"> 3. Adjustment: Observe pressure indicators (3). Turning to the right increases the setpoint (stressing the spring). Turning to the left reduces the setpoint (unstressing the spring). 	
<ol style="list-style-type: none"> 4. Falls vor oder nach dem zu regelnden Anlagenteil keine Manometer vorhanden sind, kann die Einstellung des Differenzdruckes überschlägig anhand der Skala unterhalb der Einstellschraube gemäss Einstelldiagrammen auf Seite 5 erfolgen. 		<ol style="list-style-type: none"> 4. If there are no pressure indicators installed in supply and return of the controlled loop, the differential pressure can be set by the scale according to the setpoint diagrams on page 5. 	
<ol style="list-style-type: none"> 5. Der Sollwertsteller kann plombiert werden. 	<ol style="list-style-type: none"> 5. The setpoint adjuster may be sealed. 		
de	Demontage	Dismounting	en
<p>Gefahr ! Verletzungsgefahr durch Heisswasser.</p> <ul style="list-style-type: none"> • Ventil ist ohne Antrieb offen, Abdichtung befindet sich im Antrieb. • Demontage des Differenzdruckreglerantriebes ohne vollständiges Absperren der Anlage ist nicht zulässig. 		<p>Danger ! Danger of injury by hot water.</p> <ul style="list-style-type: none"> • Valve without actuator is open, seal is in the actuator. • Dismounting of differential pressure regulator or actuator without total shut off of the transfer station is not permitted. 	



Bei Servicearbeiten am Differenzdruckregler: Pumpe und Betriebsspannung ausschalten, Absperrschieber des Rohrnetzes schliessen, Leitungen drucklos machen und ganz abkühlen lassen.

Die Wieder-Inbetriebnahme des Ventils darf nur mit vorschriftsgemäss montierten Steuerleitungen erfolgen.

de Hilfe		
Störung	Mögliche Ursache	Massnahme
Regler hält den Differenzdruck nicht konstant.	Luft im Antrieb.	<ol style="list-style-type: none"> 1. Steuerleitungsanschlüsse am Antrieb ca. 1 Umdrehung lösen. 2. Entlüften, Steuerleitung bewegen bis Medium austritt. 3. Steuerleitungsanschlüsse wieder anziehen.
Differenzdruck zu hoch.	Steuerleitung bzw. Steuerleitungsanschlüsse verschmutzt oder verstopft.	<ol style="list-style-type: none"> 1. Steuerleitung demontieren. 2. Steuerleitung, Anschlüsse an der Rohrleitung und am Antrieb mit Blende Ø1 reinigen und Durchgang überprüfen.
Ventil schliesst nicht.	Ventilsitz, Kegel oder Innengarnitur verschmutzt oder beschädigt.	<ol style="list-style-type: none"> 1. Steuerleitung abbauen. 2. Überwurfmutter SW50 lösen und Antrieb abnehmen. 3. Sitz und Kegel reinigen. 4. Bei Beschädigung Ventil austauschen.
	Membrane defekt.	Ventil austauschen.
Differenzdruck zu niedrig.	Ventil öffnet nicht: Innengarnitur verschmutzt oder beschädigt.	<ol style="list-style-type: none"> 1. Steuerleitung abbauen. 2. Überwurfmutter SW50 lösen und Antrieb abnehmen. 3. Innengarnitur reinigen. 4. Bei Beschädigung Ventil austauschen.
	Der Differenzdruck über der Anlage ist geringer als der am Differenzdruckregler eingestellte Sollwert.	Anlage überprüfen.



When doing service work on the valve, the regulator and/or the pressure tubes: Deactivate the pump and turn off the power supply, close the shutoff valves, reduce fully the pressure in the piping system and allow pipes to completely cool down. Before putting the valve into operation, make certain the pressure tubes are correctly fitted.

en Help		
Fault	Possible cause	Remedy
Regulator does not keep the differential pressure on a constant level.	Air in the actuator.	<ol style="list-style-type: none"> 1. Loosen control line connections on the actuator by one rotation. 2. Release air (move control lines until water escapes). 3. Re-tighten control line connections.
	Control lines or control line connections with orifice are dirty or blocked.	<ol style="list-style-type: none"> 1. Dismount control lines. 2. clean control lines and connections on the actuator with orifice (orifice 1) and check for leaks.
Differential pressure to high.	Valve does not close: valve seat or cone is dirty or damaged.	<ol style="list-style-type: none"> 1. Remove control lines. 2. Loosen union nut SW50 and remove actuator. 3. Clean seat and cone. 4. Replace valve if cone or seat is damaged.
	Membrane damaged.	Replace valve.
Differential pressure to low.	Valve does not open: valve seat or cone is damaged.	<ol style="list-style-type: none"> 1. Remove control lines. 2. Loosen union nut SW50 and remove actuator. 3. Clean seat and cone. 4. Replace valve if cone or seat is damaged.
	The differential pressure for the system is lower as the setpoint at the differential pressure regulator.	Check plant.

VHG519K..., DN15 ... 25 / Δp_w 15 ... 60 kPa

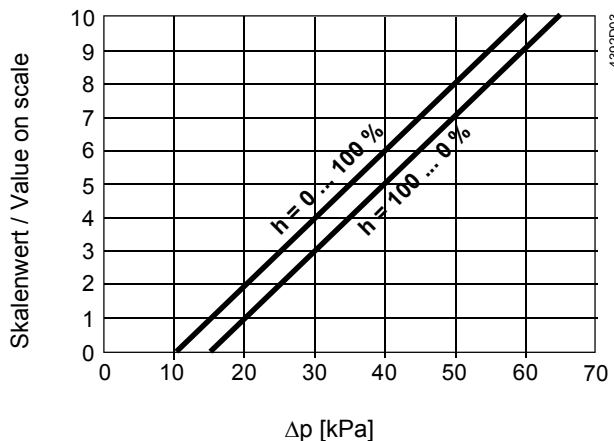

1 Drehung / Rotation = 0.83 kPa

VHG519K..., DN32 ... 50 / Δp_w 25 ... 70 kPa

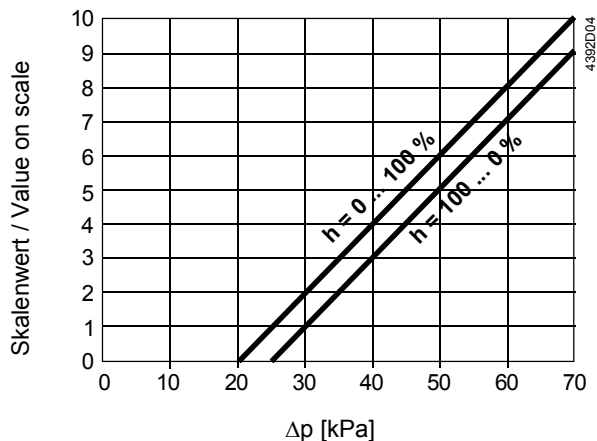

1 Drehung / Rotation = 0.83 kPa

VHG519L..., DN15 ... 25 / Δp_w 30 ... 210 kPa

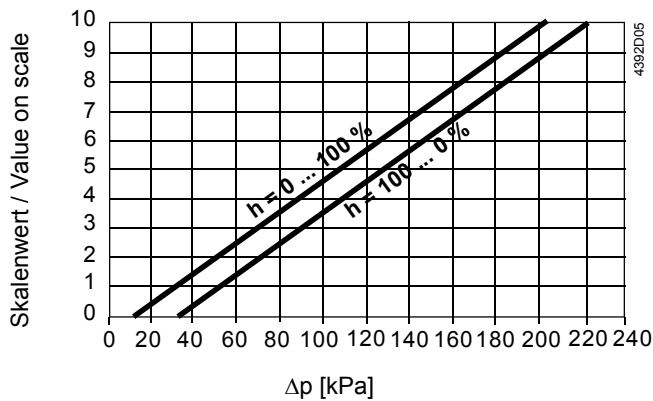

1 Drehung / Rotation = 2.37 kPa

VHG519L..., DN32 ... 50 / Δp_w 40 ... 220 kPa

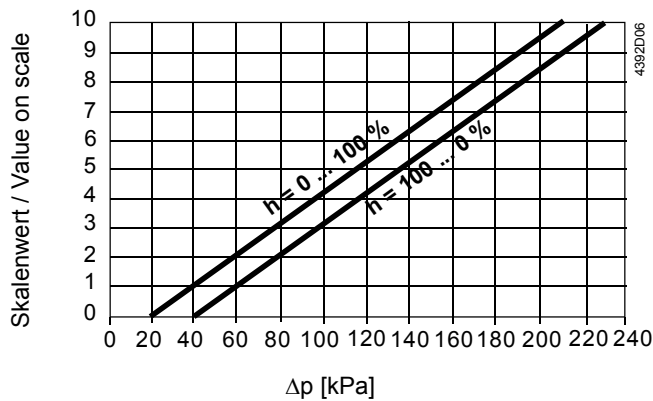

1 Drehung / Rotation = 2.37 kPa

de **Abmessungen**

en **Dimensions**

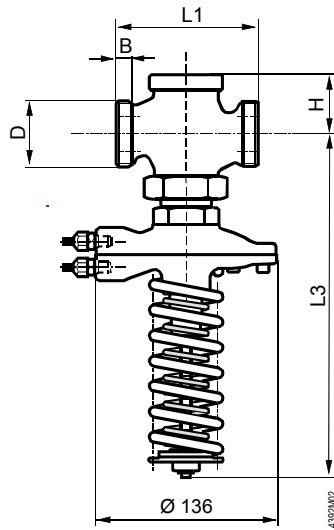

DN	D [Zoll] [Inches]	B [mm]	L1 [mm]	L3 [mm]	H [mm]	W [kg]
15	G 1 B	9	100	254	44.5	4.1
20	G 1¼ B	10	100	254	44.5	4.4
25	G 1½ B	11	105	254	44.5	4.7
32	G 2 B	12	130	274	63	6.1
40	G 2¼ B	14	140	274	63	7.0
50	G 2¾ B	16	160	274	63	9.1

Verschraubungen
Fittings

Verschraubungen mit Schweissnippel
Weldable fittings

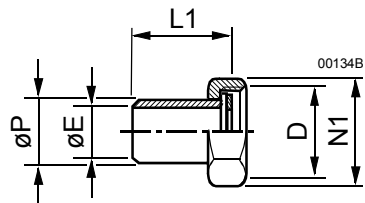

Verschraubungen mit Gewindenippel
Screwed fittings

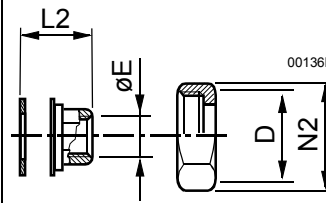

DN	Type	D [Zoll] [Inches]	ø P [mm]	ø E [mm]	L1 [mm]	N1 [mm]	W [kg]	Type	D [Zoll] [Inches]	ø E [Zoll] [Inches]	L2 [mm]	N2 [mm]	W [kg]
15	ALS20	G 1	26.8	20	41.5	41	0.10	ALG15	G 1	Rp ½	24	41	0.10
20	ALS25	G 1¼	33.7	25	41.5	50	0.16	ALG20	G 1¼	Rp ¾	25	50	0.16
25	ALS259	G 1½	33.7	29.5	27.5	56	0.2	ALG25	G 1½	Rp 1	28	55	0.2
32	ALS329	G 2	42.4	37.2	31.5	71	0.25	ALG32	G 2	Rp 1¼	32	70	0.25
40	ALS409	G 2¼	48.3	43.1	33.5	76	0.3	ALG40	G 2¼	Rp 1½	34	75	0.3
50	ALS509	G 2¾	60.3	54.5	36.5	91	0.4	ALG50	G 2¾	Rp 2	36	90	0.4